

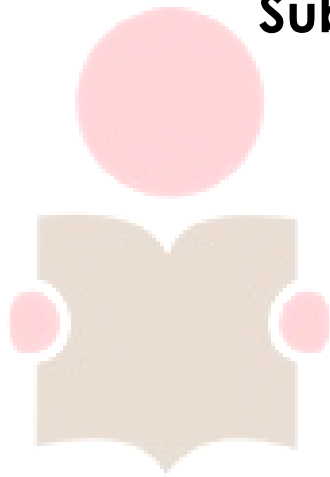

## **TENDER DOCUMENT**

**For Construction of Pipeline Extension, Water Kiosk and Fencing of Borehole Site at Balambala in Balambala ward of Balambala Sub-County, Garissa County**



**TENDER NO.  
PGI/002/04/2024**

**Pastoralist  
Girls Initiative**  
*Empower Girls, Save Community*

## TABLE OF CONTENTS

SECTION I: LETTER OF INVITATION .....	4
TENDER NOTICE .....	5
Checking.....	6
Queries during tendering.....	6
Amendment of tender documents.....	6
A.    DESCRIPTION OF THE WORKS .....	6
a.    General Requirements .....	6
SECTION III: TECHNICAL SPECIFICATIONS .....	7
SECTION IV: PASTORALIST GIRLS INITIATIVE TERMS AND CONDITIONS.....	8
1.    Closing date and time for submission of tenders.....	8
2.    Submission of tenders.....	8
3.    Opening of Tenders.....	8
4.    Clarification of Tenders.....	8
5.    Preliminary Examination .....	9
6.    Language of offers .....	9
7.    Period of validity of offers .....	9
8.    Currency.....	9
9.    Cost of Tendering.....	9
11.   Tender Prices.....	9
12.   Type of contract .....	9
14.   Tenderer's Memorandum .....	10
15.   Opening of tenders.....	10
16.   Evaluation of tender .....	10
17.   Site Visit.....	10
18.   Cancellation of the tender procedure .....	10
19.   Data Protection.....	10
TENDER DATA SHEET.....	11
(a)   Use of Contract Documents and Information.....	13
(b)   Contractor in the performance of the Contract.....	13
(c)   Inspection and Tests.....	13
(d)   Goods, Personnel and Equipment.....	13
(h)   Payment.....	14
(i)   Prices .....	15
(j)   Assignment .....	15
(k)   Subcontracts.....	15

(m)	Termination for Default.....	15
(n)	Liquidated Damages.....	15
(o)	Resolution of Disputes.....	15
(p)	Language and Law .....	15
(q)	Force Majeure .....	16
SECTION VI: STANDARD FORMS .....		17
A.	TENDERER'S RELEVANT EXPERIENCE.....	18
B.	TENDERER'S DECLARATION .....	19
C.	CONFIDENTIAL BUSINESS QUESTIONNAIRE FORM.....	21
D.	CONTRACT FORM .....	23
E.	LETTER OF NOTIFICATION OF AWARD.....	24
ANNEXE 1 .....		25
ANNEXE 2.....		26
<b>ADDITIONAL TENDERING FORMS .....</b>		<b>28</b>
<b>PERSONNEL FORM.....</b>		<b>28</b>
<b>EQUIPMENT FORM.....</b>		<b>28</b>
<b>WORK METHODOLOGY .....</b>		<b>29</b>
BILLS OF QUANTITIES.....		30
TECHNICAL EVALUATION CRITERIA.....		38
FINANCIAL EVALUATION CRITERIA.....		39
NON STAFF CODE OF CONDUCT .....		40



## SECTION I: LETTER OF INVITATION

**REF: PGI/002/04/2024**

**Dear Sir/Madam**

**SUBJECT: TENDER FOR Construction of Pipeline Extension, Water Kiosk and Fencing of Borehole Site at Balambala in Balambala ward of Balambala Sub-County, Garissa County**

With regards to the above-mentioned subject invitation to tender, please find below the documents, which constitute the tender report.

- i. Letter of Invitation to tender
- ii. Tender Notice
- iii. Instructions to tender
- iv. Technical Specifications
- v. Pastoralist Girls Initiative (PGI) Terms and conditions
- vi. General conditions of contract
- vii. Standard forms
- viii. Pastoralist Girls Initiative Child Protection Policy

We look forward to receiving your tender **bid** as per the tender notice instructions.

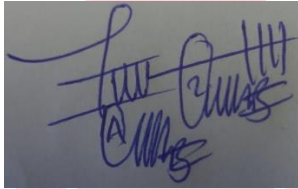

**Abdinoor Bashir Takal**  
**Procurement Officer**

Pastoralist  
Girls Initiative

*Empower Girls, Save Community*

## TENDER NOTICE

### **Construction of Pipeline Extension, Water Kiosk and Fencing of Borehole Site at Balambala in Balambala ward of Balambala Sub-County, Garissa County**

Pastoralist Girls Initiative (PGI) is an indigenous, Garissa based Non-Governmental Organization that was registered in 2008. PGI works to enhance the capacity of women and girls from ASAL communities to develop resilience, economic growth and adaptation to climate change. In doing so we work with a wide range of stakeholders interested in the EMPOWERMENT of women and girls from the pastoralist communities to achieve their potential and improve the quality of their lives as individuals and collectively that of the entire community. PGI works largely focuses on girls and women to develop their leadership skills and empower them to take lead in addressing challenges that affect their development including early marriages, female genital mutilation, and education amongst others. It supports women to initiate income-generating activities as well as develop resilient skills to cope with ever changing environmental factors. PGI's vision is: 'Empowered ASAL communities realizing their fullest potential and leading dignified human lives'. Its mission is: 'To promote sustainable development by enhancing the capacities of ASAL communities through integrated development approaches'. The strapline is enabling prosperous futures interest.

To access this tender document, tenderers shall download free of charge from Pastoralist Girls Initiative website; [www.pastoralistgirls.org](http://www.pastoralistgirls.org).

Tenderers must **quote REF: PGI/002/04/2024** during the application.

Bid documents should be dropped at **the PGI Garissa Office tender box at the reception.**

Tenders **MUST** be received not later than **10:00 a.m. Thursday 2nd May, 2024**. Documents presented after **the deadline will NOT be accepted**. Tenders will be opened **Thursday 2nd May, 2024 at 10:30 a.m. at PGI Offices-National Bank Building, Garissa First floor**. All bidders or their representatives are welcome to the opening of the tender.

Completed tender documents should be addressed to: -

**Pastoralist Girls Initiative**  
P.O. Box 457 – 70100,  
Garissa, Kenya.

**For any inquiries please contact:**  
**[procurement@pastoralistgirls.org](mailto:procurement@pastoralistgirls.org)**

## **SECTION II: INSTRUCTIONS TO TENDERERS**

### **Checking**

The Tenderer is required to check the numbers of the pages and should any be found to be missing or in duplicate or the figures or writing indistinct, he must inform PGI immediately and have the same rectified. Should the Tenderer be in doubt about the precise meaning of any words or figures he must inform PGI in order that the correct meaning may be decided upon before the date for the submission of the tender.

No liability whatsoever will be admitted nor claim allowed in respect of errors in the tender due to mistakes in the Bills of Quantities which should have been rectified in the manner spelt above.

### **Queries during tendering**

Any doubt or perceived ambiguity as to the meaning or intention of the tender documents, or any other question arising shall be communicated in writing to PGI before the tender is submitted. PGI will upon receipt of any such query, set out the intent and meaning of any part. Written copies of PGI's response including a description of the inquiry but without identifying its source, will be sent to all prospective tenderers who have been issued with the tender documents.

### **Amendment of tender documents**

"At any time prior to the deadline for submission of tenders, PGI may, for any reason, whether at his own initiative or in response to a clarification requested by a prospective tenderer, modify the tender documents by the issuance of an Addendum.

The Addendum will be sent in writing or by cable to all invited tenderers who have been issued with the tender documents and will be binding upon them. Prospective tenderers shall promptly acknowledge receipt thereof by letter or cable to PGI."

In order to afford prospective tenderers reasonable time in which to take an addendum into account in preparing their tenders, PGI may, at his own discretion, extend the deadline for the submission of tenders

## **A. DESCRIPTION OF THE WORKS**

The works involves the following:

- i. Construction of HDPE Pipelines and associated appurtenances
- ii. Construction of a standard kiosk.
- iii. Fencing of Balambala Borehole site

### **a. General Requirements**

These specifications describe the requirements for construction of water supply pipes, water kiosk and fencing to promote access to clean water to the Balambala communities.

The site for the proposed works shall be Balambala village in Balambala; 0°01'32"S 39°03'47"E, about 130 km from Garissa town.

**The tenderers MUST present information along with their offers as follows:**

- (i) Shortest possible delivery period.
- (ii) Staff Information on proper representatives.
- (iii) Copy of certificate of Registration/Incorporation
- (iv) Copy of Valid tax compliance Certificate
- (v) Valid Business Permit
- (vi) Registration with National Construction Authority

- (vii) Proof of experience in carrying out the proposed works. Submit names/references of three (3) clients where similar services have been successfully implemented within the last two (2) years.
- (viii) Audited Accounts for the last two (2) years (2021 and 2022)
- (ix) Provide a detailed production to delivery work plan.
- (x) Submit a brief company profile indicating expertise in the works.
- (xi) Serialized Document
- (xii) 2% Bid Security of the Amount Quoted
- (xiii) Must fill the form of tender in the format provided.

The bidder should bear in mind that the work plan proposed should be reasonable simple, with minimum timeline provided. The contractor should be ready to work within those timelines and lack of delivery within the proposed work plan will attract a penalty or cancellation of the contract.

### **SECTION III: TECHNICAL SPECIFICATIONS**

All materials, equipment and testing apparatus etc. to be furnished and Works to be executed by the Contractor in this Contract shall conform to the requirements of the latest Kenya Standards, International Standards Organization (ISO), European Norm (EN), Deutsches Institut für Normung (DIN), British Standards (BS) or other approved applicable Standards in Kenya.

Materials to be purchased shall be from well recognized manufacturers whose products are standardized and controlled by any recognized Standards Organization.

The Contractor is referred to General Specifications for Building Works – 1976 Edition Pages B1 – B2 and must allow for all costs in complying with these clauses

All dimensions and measurement units shall be in S.I. units unless otherwise stated.

The following is required from the pipe manufacturer:

- a) All High-Density Polyethylene (HDPE) Pipes must be from class PE 100 and minimum strength at 20°C with Nominal Pressure and Standard Dimensions Ratio (SDR) as specified in the purchase order
- b) All HDPE pipe and fittings shall be from a single manufacturer. The manufacturer is responsible for compatibility between pipe materials, fittings and appurtenances
- c) All molded fittings and fabricated fittings shall be fully pressure rated to match the pipe SDR pressure rating to which they are made
- d) The internal diameter and external surfaces of pipes must smooth, clean and free from scoring, cavities and other surface defects which may affect pipe performance
- e) All pipes shall be checked visually, inside and out for cosmetic defects (grooves, pits, hollows, etc.)
- f) Pipes outside diameter, wall thickness, and length shall be measured randomly before acceptance of a delivery.
- g) Pipe marking shall be examined and checked for accuracy. The following shall be continuously indent printed on the pipe or spaced at intervals not exceeding 1.5m:
  - i. Name and/or trademark of the pipe manufacturer.
  - ii. Nominal pipe size.
  - iii. The material grade (PE100).
  - iv. Nominal Pressure (PN)
  - v. Manufacturing standard reference as required.
  - vi. Serial number
  - vii. The date of manufacture
  - viii. The color of the pipes shall be black with blue stripes. The material for stripes shall be of the same type of resin as used in the compound for the pipe.
- h) The pipe manufacturer shall provide test certification before delivery of every production batch. The pipe suppliers shall, as and when requested by the purchasers, furnish results carried out in accordance with requirements

- i) The pipe manufacturer shall provide a warranty against manufacturing defects of material and workmanship during processing. The manufacturer shall replace at no expense to the contractor any defective pipe/fitting material including labor within the warranty period.
- j) The pipes to be supplied alongside the manufacturer's brochures.

#### PROJECT HANDOVER:

The handover report should include but not limited to the following:

- i. Proof that all components are working and in good condition
- ii. Technical operation reports
- iii. Technical specifications and manuals for all components
- iv. Maintenance plans and schedules
- v. Existing warranties and guaranties.

### SECTION IV: PASTORALIST GIRLS INITIATIVE TERMS AND CONDITIONS

#### 1. Closing date and time for submission of tenders Thursday 2nd May, 2024 at 10:00 a.m

#### 2. Submission of tenders

Tenders to be submitted to the tender Box in PGI Garissa Office with sealed envelopes marked by company stamp to the below physical address:

**PASTORALIST GIRLS INITIATIVE OFFICE  
NATIONAL BANK BUILDING  
First Floor  
P.O. Box457 – 70100,  
Garissa, Kenya.**

Contractors must quote **Ref: PGI/002/04/2024** in their applications and the Construction company name, telephone and email address at the back of the cover envelope.

#### 3. Opening of Tenders

- i. Pastoralist Girls Initiative (PGI) will open all tenders in the presence of tenderers' representatives who choose to attend, on **2nd May, 2024 at 10:30 a.m.** and in the location specified in the Invitation to Tender.
- ii. The tenderers' or their representatives are encouraged to attend and will be required to sign a register evidencing their attendance.
- iii. The tenderers' names, tender modifications or withdrawals, tender prices, discounts and such other details as PGI, at its discretion, may consider appropriate, will be announced at the opening.

#### 4. Clarification of Tenders

- i. To assist in the examination, evaluation and comparison of tenders PGI may, at its discretion, ask the tenderer for clarification of its tender. The request for clarification and the response shall be in writing, and no change in the prices or substance of the tender shall be sought, offered, or permitted.
- ii. Any effort by the tenderer to influence PGI in its tender evaluation, tender comparison or contract award decisions will result in the Rejection of the tenderers' tender.



## **5. Preliminary Examination**

Prior to the technical evaluation, PGI will determine the substantial responsiveness of each tender to the tender documents. For purposes of this paragraph, a substantially responsive tender is one which conforms to all terms and conditions of tendering. PGI determination of a tender's responsiveness is to be based on the contents of the tender itself without recourse to extrinsic evidence.

The Preliminary Examination will check for the existence of the following mandatory documents:

- (i) Copy of certificate of Registration/Incorporation
- (ii) Copy of Valid tax compliance Certificate
- (iii) Valid Business Permit
- (iv) Registration with National Construction Authority
- (v) Proof of experience in carrying out the proposed works. Submit names/references of three (3) clients where similar services have been successfully implemented within the last two (2) years.
- (vi) Audited Accounts for the last two (2) years (2021 and 2022)
- (vii) Provide a detailed production to delivery work plan.
- (viii) Submit a brief company profile indicating expertise in the works.
- (ix) Must fill the form of tender in the format provided
- (x) Must serialize the document
- (xi) 2% Bid Security of the Amount Quoted

## **6. Language of offers**

Tender should be received in English Language

## **7. Period of validity of offers**

This bid will be valid for a minimum of ninety (90) days from date of tender submission.

## **8. Currency**

The currency in this tender should be in Kenyan Shillings (Kshs)

## **9. Cost of Tendering**

The contractor shall bear all costs associated with the preparation and submission of its tender, and PGI, will in no case be responsible or liable for those costs, regardless of the conduct or outcome of the tendering process.

## **10. Tender Form**

- a) The Tenderer shall complete the Tender Form and the appropriate Price Schedule furnished in the Tender documents, including the sample of goods to be supplied, a brief description of the goods and prices.

## **11. Tender Prices**

The Tenderer shall indicate on the appropriate Price Schedule the unit prices and total tender price for the works under the contract. Prices must be inclusive of VAT and any other taxes.

## **12. Type of contract**

The contract offer is for specific quantity as described in the Bill of Quantities.

## **13. Contents**

The tender document comprises the documents listed below, and addenda issued in accordance with Instructions to contractors

- I. Letter of Invitation to tender
- II. Tender Notice

- III. Instructions to tender
- IV. PGI Terms and conditions
- V. General conditions of contract
- VI. Specifications and drawings
- VII. Tenderer's Relevant Experience
- VIII. Tender technical evaluation
- IX. Tender's Declaration

The Contractor is expected to examine all instructions, forms, terms and specifications in the tender documents. Failure to furnish all information required by the tender documents or to submit a tender not substantially responsive to the tender documents in every respect will be at the contractor's risk and may result in the rejection of its tender.

#### **14. Tenderer's Memorandum**

All tenders submitted shall (mandatory) include copies of the following documents: -

- (a) Copy of certificate of Registration/Incorporation
- (b) Copy of Valid tax compliance Certificate
- (c) Valid Business Permit
- (d) Registration with National Construction Authority
- (e) Proof of experience in carrying out the proposed works. Submit names/references of three (3) clients where similar services have been successfully implemented within the last two (2) years.
- (f) Audited Accounts for the last two (2) years (2021 and 2022)
- (g) Provide a detailed production to delivery work plan.
- (h) Submit a brief company profile indicating expertise in the works.
- (i) Must fill the form of tender in the format provided
- (j) Fully filled tender document and returned in its original form without missing pages.
- (k) 2% Bid Security of the Amount Quoted

#### **15. Opening of tenders**

All tenders will be opened on **2nd May 2024 at 10:30 a.m** by PGI procurement committee and bidder or their representatives who choose to attend are welcomed to witness the opening at PGI Garissa Office. Thereafter PGI procurement committee will carry on the evaluation of the tender process.

#### **16. Evaluation of tender**

The PGI procurement committee will evaluate all bids based on specifications, references, capacity, capability, financial and experience factors. Bids will not be evaluated on price alone but also on administrative compliance in order to be qualified. PGI is not bound to accept the lowest bidder. The decision of the procurement committee will be final and the outcome of the tender process will be communicated via email.

#### **17. Site Visit**

The tenderers are highly advised to visit the site and acquaint themselves with the conditions on site before presenting their tenders. Where works are described as "to match existing, the Contractor must ensure that. No claim for want of knowledge arising from failure to ascertain the site conditions will be entertained or allowed under any circumstances.

#### **18. Cancellation of the tender procedure**

PGI Procurement committee has the liberty to cancel this process based on valid reasons and will state reasons for such actions.

#### **19. Data Protection**

PGI guarantees that all procurement activities are confidential and transparently documented for internal and donor audit purposes.

## TENDER DATA SHEET

<b>A. General</b>		
1.1	Reference number of the Invitation to Tender (ITT)	<b>PGI/002/04/2024</b>
1.2	Procuring Entity is	Pastoralist Girls Initiative(PGI)
1.3	Name of the Project	<b>Construction of Pipeline Extension, Water Kiosk and Fencing of Borehole Site at Balambala in Balambala ward of Balambala Sub-County, Garissa County</b>
1.4	The components include the following:	<ul style="list-style-type: none"> <li>i. Construction of HDPE Pipelines and associated appurtenances</li> <li>ii. Construction of a standard kiosk.</li> <li>iii. Fencing of Balambala Borehole site</li> </ul>
1.5	The Procuring Entity shall use the electronic procurement system only to upload the tender documents on the website for access by the bidders but the bidders <b>MUST NOT</b> submit their bids electronically.	
<b>B. Tendering Document</b>		
2.1	The tenderers are highly advised to visit the site and acquaint themselves with the conditions on site before presenting their tenders. No claim for want of knowledge arising from failure to ascertain the site conditions will be entertained or allowed under any circumstances.	
2.2	<b>PARTICULARS OF APPENDIX TO INSTRUCTIONS TO TENDERS</b>	Any questions in writing should reach the Procuring Entity not <b>later 26th April, 2024</b>
<b>C. Preparation of Tenders</b>		
3.1	Alternative Tenders <i>“shall not be</i> considered.	
3.2	Alternatives to the Time Schedule <i>shall not be</i> permitted.	
3.3	The Tender document <b>must be</b> serialized	
3.4	Tenderers shall quote for the following components or services on a single-responsibility basis: <b>As per the BoQ bills</b>	
3.4	<b>Place of destination:</b>	<b>Balambala</b> village in Balambala Sub- County, Garissa County.
3.5	<b>The prices quoted by the Tenderer shall not be subject to adjustment during the Performance of the Contract.</b>	
3.6	<b>The Tenderer is required to quote in Kenya Currency the portion of the Tender price that corresponds to expenditures incurred in that currency.</b>	
3.7	<b>Tender validity period</b>	<b>90 days.</b>
3.8	<b>Tender price adjustment</b>	<b>Not Applicable</b>
3.9	<b>Bid Security</b>	<b>Bid Security of 2% of the Total Amount Shall be required</b>
3.10	<b>Standstill Period</b>	<b>The Standstill Period is 5 Calendar Days after the date the Procuring Entity has transmitted to all Tenderers that submitted a Tender, the</b>

		Notification of its Intention to Award the Contract to the successful Tenderer.
3.11	Procurement-related Complaint Procedures	<p>The procedures for making a Procurement-related Complaint are detailed in the “Notice of Intention to Award the Contract” herein and are also available from the PPRA website <a href="mailto:info@ppra.go.ke">info@ppra.go.ke</a> or <a href="mailto:complaints@ppra.go.ke">complaints@ppra.go.ke</a>.</p> <p>For the attention: Abdinoor Bashir  Title/position: Procurement officer  Procuring Entity: Pastoralist Girls Initiative (PGI)  Email address: <a href="mailto:procurement@pastoralistgirls.org">procurement@pastoralistgirls.org</a></p> <p>In summary, a Procurement-related Complaint may challenge any of the following:</p> <ol style="list-style-type: none"> <li>1.the terms of the Tendering Documents; and</li> <li>2.the Procuring Entity’s decision to award the contract.</li> </ol>



## **SECTION V: GENERAL CONDITIONS OF CONTRACT**

### **Definitions**

In this Contract, the following terms shall be interpreted as indicated:

- i. "The Contract" means the agreement entered into between PGI and the contractor as recorded in the Contract Form signed by the parties, including all attachments and appendices thereto and all documents incorporated by reference therein.
- ii. The term "The Contractor" means the individual or firm supplying the Goods under this Contract to PGI.
- iii. "The Contract Price" means the price payable to the Tenderer under the contract for the full and proper performance of its contractual obligations.
- iv. The Contractor's Bid is the completed bidding document submitted by the Contractor to PGI
- v. Bill of Quantities means the priced and completed Bill of Quantities forming part of the Bid
- vi. The Works are what the Contract requires the Contractor to construct, install, and hand over
- vii. "PGI" means the procuring organization who employs the Contractor to carry out the Works.

### **(a) Use of Contract Documents and Information**

The Contractor shall not, without PGI 's prior written consent, disclose the Contract, or any provision thereof, or any specification, or information furnished by or on behalf of PGI in connection therewith, to any person other than a person employed by PGI.

### **(b) Contractor in the performance of the Contract**

The Contractor shall not, without PGI 's prior written consent, make public or advertise the fact that it is implementing the works for the PGI, nor shall contractor in any way whatsoever use the name and emblem of PGI.

### **(c) Inspection and Tests**

PGI or its representative shall have the right to inspect and/or test the goods to confirm their conformity to the Contract specifications. PGI shall notify the Contractor in writing, in a timely manner, of the identity of any representatives retained for these purposes.

The inspections and tests may be conducted on the premises of the Contractor or its sub-contractor (s), while work is in progress, at point of delivery and/or at the good's final destination. If conducted on the premises of the Contractor or its sub-contractor(s), all reasonable facilities and assistance, including access to production data, shall be furnished to the inspectors at no charge to PGI.

Should any inspected or tested works fail to conform to the specifications, PGI may reject the works, and the Contractor shall either replace the rejected materials or make good part of the works to meet specification requirements free of cost to PGI.

PGI 's right to inspect, test and, where necessary, reject the works and materials after delivery shall in no way be limited or waived by reason of the works having previously been inspected, tested, and passed by PGI or its representative prior to the goods' delivery.

Nothing in the paragraphs stated above shall in any way release the Contractor from any warranty or other obligations under this contract.

### **(d) Goods, Personnel and Equipment**

The Contractor shall employ the key personnel and use correct to carry out the Work. If PGI or Contractor determines, that any employee of the Contractor be determined to have engaged in Fraud and Corruption during the execution of the Works, then that employee shall be removed.

From the Starting Date until the Completion Date, the risks of personal injury, death, and loss of or damage to property (including, without limitation, the Works, Plant, Materials, and Equipment) which are not PGI's risks are Contractor's risks.

The Contractor is required to procure goods from local manufacturers or approved local distributors. Any goods, works and production processes with characteristics that have been declared by the relevant national environmental protection agency or by other competent authority as harmful to human beings and to the environment shall not be eligible for procurement.

**(e) Contractor to Construct the Works**

The Contractor shall construct and install the Works in accordance with the Specifications and Drawings. The Contractor shall be responsible for the safety of all activities on the Site.

The Works to Be Completed by the Intended Completion Date. The construction period shall be **1½ months**

**(f) Correction of Errors**

Tenders that are substantially responsive will be checked by PGI for any arithmetic errors in computation and summation.

PGI shall not undertake any correction of errors.

Bids found to contain arithmetic errors will be rejected.

**(g) Award of Contract**

The award of the Contract will be made to the tenderer whose tender has been determined to be substantially responsive to the tendering documents and who has offered the lowest evaluated tender price, provided that such tenderer has been determined to be eligible.

PGI reserves the right to accept or reject any tender, and to cancel the tendering process and reject all tenders, at any time prior to the award of Contract, without thereby incurring any liability to the affected tenderer or tenderers or any obligation to inform the affected tenderer or tenderers of the grounds for the action.

The tenderer whose tender has been accepted will be notified of the award prior to expiration of the tender validity period in writing or by email. At the same time the other tenderers shall be informed that their tenders have not been successful.

Contract price variations shall not be allowed.

The Contractor is expected to start works immediately after award of the Contract.

**(h) Payment**

The Bill of Quantities shall contain priced items for the Works to be performed by the Contractor. The Bill of Quantities is used to calculate the Contract Price. The Contractor will be paid for the quantity of the work accomplished at the rate in the Bill of Quantities for each item.

Unless otherwise stated, all payments and deductions shall be paid or charged in the proportions of currencies comprising the Contract Price.

Items of the Works for which no rate or price has been entered in shall not be paid for by PGI and shall be deemed covered by other rates and prices in the Contract.

**(i) Prices**

Prices charged by the Contractor for goods delivered and services performed under the Contract shall not, with the exception of any price adjustments authorized in General conditions of contract, vary from the prices by the Contractor in its Tender.

**(j) Assignment**

The Contractor shall not assign, transfer, sublet or subcontract in whole or in part, its obligations to perform under this Contract, except with PGI 's prior written consent.

**(k) Subcontracts**

The Contractor shall notify PGI in writing of all subcontracts awarded under this Contract if not already specified in the Tender. Such notification, in the original Tender or later, shall not relieve the Contractor from any liability or obligation under the Contract.

**(l) Progress reports**

Weekly and monthly progress reports shall be prepared by the Contractor and submitted to PGI. Each report shall include charts and detailed descriptions of progress, manufacturing and delivery details, tests, safety statistics, comparison of actual and planned progress photographs, etc.

Reporting shall continue until the Contractor has completed all work which is known to be outstanding at the completion date stated in the Taking-Over Certificate for the Works.

**(m) Termination for Default**

PGI may, without prejudice to any other remedy for breach of Contract, by written notice of default sent to the Contractor, terminate this Contract in whole or in part.

- i. If the Contractor fails to deliver any or all of the goods within the period(s) specified in the Contract, or within any extension thereof granted by PGI.
- ii. If the Contractor fails to perform any other obligation(s) under the Contract.
- iii. If the Contractor, in the judgment of PGI has engaged in corrupt or fraudulent practices in competing for or in executing the Contract.

In the event PGI terminates the Contract in whole or in part, it may procure, upon such terms and in such manner as it deems appropriate, goods similar to those undelivered, and the Contractor shall be liable to PGI for any excess costs for such similar Goods.

**(n) Liquidated Damages**

If the Contractor fails to deliver any or all of the goods within the period (s) specified in the contract, PGI shall, without prejudice to its other remedies under the contract, deduct from the contract prices liquidated damages sum equivalent to 5% of the price of the undelivered goods up to a maximum deduction of 10% of the undelivered goods. After this the Contractor may consider termination of the contract.

**(o) Resolution of Disputes**

PGI and the Contractor shall make every effort to resolve amicably by direct informal negotiation any disagreement or dispute arising between them under or in connection with the contract.

If after thirty (30) days from the commencement of such informal negotiations both parties have been unable to resolve amicably a contract dispute, the provision of the arbitration Act of the Laws of Kenya shall apply.

**(p) Language and Law**

The Language of the contract and the law governing the contract shall be English language and the laws of Kenya respectively unless otherwise stated.

**(q) Force Majeure**

The Contractor shall not be liable for forfeiture of its performance security, or termination for default if and to the extent that its delay in performance or other failure to perform its obligations under the Contract is the result of an event of Force Majeure.





## SECTION VI: STANDARD FORMS

### Notes on the sample Forms

**Tenders Relevant Experience-** this form/table must be completed using the format provide to summarize the major relevant supplies/services carried out in the course of the past 3 years. The number of references provided must not be less than 4 companies.

**Form of Tender** - The Form of Tender must be completed by the tenderer and submitted with the tender documents. It must also be duly signed by duly authorized representatives of the tenderer.

**Confidential Business Questionnaire Form** -This form must be completed by the tenderer and submitted with the tender documents.

**Contract Form** -The Contract Form shall not be completed by the tenderer at the time of submitting the tender. The Contract Form shall be completed after contract award and should incorporate the accepted contract price.



**A. TENDERER'S RELEVANT EXPERIENCE**

Tender reference PGI/ 002/04/2024

NGO/Company Name	Description of Contract	Total Contract Value	Dates	Contact Details in NGO/Co.	Related Services



## B. TENDERER'S DECLARATION

### Form of Tender

Date: -----

Tender No. -----

**PASTORALIST GIRLS INITIATIVE (PGI)**  
**P.O. Box 457, 70100,**  
**Garissa, Kenya.**

In response to your invitation to tender for the above contract, we, the undersigned, hereby declare that:

1. Having examined and accepted in full the content of the dossier for invitation we hereby accept its provisions in their entirety, without reservations or restriction. We, the undersigned, offer to construct and complete the Works and remedy any defects in accordance with the Conditions of Contract, Specifications, Drawings and Bills of Quantities for the execution of **Construction of Pipeline Extension, Water Kiosk and Fencing of Borehole Site at Balambala in Balambala ward of Balambala Sub-County, Garissa County** for the sum of Kshs .....Amount in words (.....) or such other sums as may be ascertained in accordance with the Schedule of Prices attached herewith and made part of this tender.
2. We undertake, if our tender is accepted, to deliver the goods in accordance with the delivery schedule specified.
3. If our tender is accepted we will grant a discount of ..... [%].
4. We agree to abide by this tender for a period of 7 days from the date fixed for Tender opening of the Instructions to Tenderers, and it shall remain binding upon us and may be accepted at any time before the expiration of the period.
5. Until a formal Contract is prepared and executed, this tender, together with your written acceptance thereof and your notification of award, shall constitute a binding Contract between us.
6. We understand that you are not a bound to accept the lowest or any TENDER you may receive.
7. We confirm that we are not engaged in any corrupt, fraudulent, collusive or coercive practices and acknowledge that if evidence contrary to this exists, PGI reserves the right to terminate the contract with immediate effect.
8. The code of conduct to which PGI expects all of its contractors to respect is as per the points listed below and we confirm that we adherer to this code.
  - Employment is freely chosen
  - The rights of staff to freedom of association and to collective bargaining are respected.
  - Working conditions are safe and hygienic
  - No exploitation of children is tolerated.
  - Wages paid are adequate to cover the cost of a reasonable living
  - Working hours are not excessive
  - No discrimination is practiced.
  - No harsh or inhumane treatment of staff is tolerated.
  - Environmental Standards are adhered to.
9. We affirm as a minimum, comply with all statutory and other legal requirements relating to environmental impacts of our business in: -

- Waste management
- Packaging and paper
- Conservation
- Energy use
- Sustainability

Dated this -----day of -----20-----

-----  
 (Signature) (In the capacity of)  
 Duly authorized to sign tender for and on behalf of

Company Name: -----

Title of Signatory: -----

Email Address: -----

Tel. No. -----

Physical Address: -----

Company Stamp:

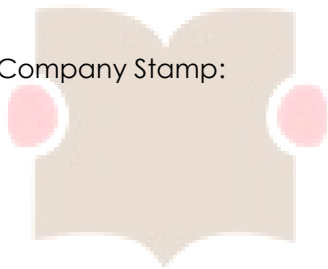

Pastoralist  
 Girls Initiative  
*Empower Girls, Save Community*

**C. CONFIDENTIAL BUSINESS QUESTIONNAIRE FORM**

You are requested to give the particulars indicated in Part 1 and either Part 2(a), 2(b) or 2 (c) whichever applied to your type of business  
 You are advised that it is a serious offence to give false information on this form

**Part 1 – General:**

Business Name  
 .....

Location of business premises.  
 .....

Plot No..... Street/Road  
 .....

Postal Address ..... Tel No. .... Mobile.....

Email .....

Nature of Business,  
 Registration Certificate No.  
 .....

Maximum value of business which you can handle at any one time – Kshs.....

Name of your bankers .....

Branch .....

<b>Part 2 (a) – Sole Proprietor</b>																									
Your name in full ..... Age .....																									
Nationality ..... Country of origin .....																									
• Citizenship details .....																									
<b>Part 2 (b) Partnership</b>																									
Given details of partners as follows:																									
<table style="width:100%; border-collapse: collapse;"> <thead> <tr> <th style="width:5%;"></th> <th style="width:30%;">Name</th> <th style="width:20%;">Nationality</th> <th style="width:30%;">Citizenship Details</th> <th style="width:15%;">Shares</th> </tr> </thead> <tbody> <tr> <td>1.</td> <td>.....</td> <td>.....</td> <td>.....</td> <td>.....</td> </tr> <tr> <td>2.</td> <td>.....</td> <td>.....</td> <td>.....</td> <td>.....</td> </tr> <tr> <td>3.</td> <td>.....</td> <td>.....</td> <td>.....</td> <td>.....</td> </tr> <tr> <td>4.</td> <td>.....</td> <td>.....</td> <td>.....</td> <td>.....</td> </tr> </tbody> </table>		Name	Nationality	Citizenship Details	Shares	1.	.....	.....	.....	.....	2.	.....	.....	.....	.....	3.	.....	.....	.....	.....	4.	.....	.....	.....	.....
	Name	Nationality	Citizenship Details	Shares																					
1.	.....	.....	.....	.....																					
2.	.....	.....	.....	.....																					
3.	.....	.....	.....	.....																					
4.	.....	.....	.....	.....																					
<b>Part 2 (c) – Registered Company</b>																									
Private or Public .....																									
State the nominal and issued capital of company-																									
Nominal Kshs.																									
Issued Kshs.																									
Given details of all directors as follows																									
<table style="width:100%; border-collapse: collapse;"> <thead> <tr> <th style="width:5%;"></th> <th style="width:30%;">Name</th> <th style="width:20%;">Nationality</th> <th style="width:30%;">Citizenship Details</th> <th style="width:15%;">Shares</th> </tr> </thead> <tbody> <tr> <td> </td> <td>.....</td> <td>.....</td> <td>.....</td> <td>.....</td> </tr> </tbody> </table>		Name	Nationality	Citizenship Details	Shares		.....	.....	.....	.....															
	Name	Nationality	Citizenship Details	Shares																					
	.....	.....	.....	.....																					

1.....
2.....
3.....
4.....
5.....

Date .....	Signature of Candidate .....
------------	------------------------------

If a Kenya Citizen, indicate under "Citizenship Details" whether by Birth, Naturalization or registration.

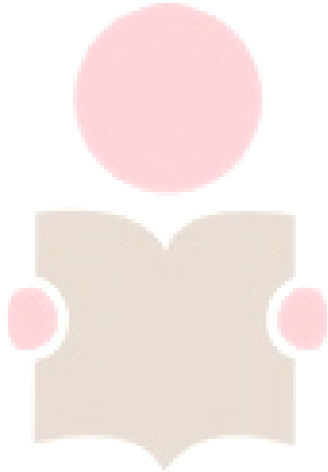

# Pastoralist Girls Initiative

*Empower Girls, Save Community*

**D. CONTRACT FORM**

THIS AGREEMENT made the \_\_\_\_\_ day of \_\_\_\_\_ 20 \_\_\_\_\_ between The PGI (hereinafter called "the PGI) on the one part and ..... [name of tenderer] of ..... [city and County of tenderer] (hereinafter called "the tenderer") of the other part;

WHEREAS the PGI invited tenders for certain goods] and has accepted a tender by the tenderer for the supply of those goods in the sum of ..... [contract price in words and figures] (hereinafter called "the Contract Price).

**NOW THIS AGREEMENT WITNESSETH AS FOLLOWS:**

1. In this Agreement words and expressions shall have the same meanings as are respectively assigned to them in the Conditions of Contract referred to:
2. The following documents shall be deemed to form and be read and construed as part of this Agreement :
  - (a) Instructions to tender
  - (b) Tender Form and the Price Schedule submitted by the tenderer
  - (c) the Schedule of Requirements
  - (d) the Technical Specifications
  - (e) the General Conditions of Contract
  - (f) the Special Conditions of contract; and
  - (g) the PGI Notification of Award

In consideration of the payments to be made by PGI to the tenderer as hereinafter mentioned, the tender hereby covenants with the PGI to provide the goods and to remedy defects/mismatches/errors therein in conformity in all respects with the provisions of the Contract. PGI hereby covenants to pay the tenderer in consideration of the provisions of the goods and the remedying of defects therein, the Contract Price or such other sum as may become payable under the provisions of the Contract at the times and in the manner prescribed by the contract. IN WITNESS whereof the parties hereto have caused this Agreement to be executed in accordance with their respective laws the day and year first above written.

Signed, sealed, delivered by \_\_\_\_\_ the \_\_\_\_\_ (for the PGI)  
Signed, sealed, delivered by \_\_\_\_\_ the \_\_\_\_\_ (for the tenderer in the presence of \_

\_\_\_\_\_  
(Amend accordingly if provided by Insurance Company)

**E. LETTER OF NOTIFICATION OF AWARD**

Pastoralist Girls Initiative

\_\_\_\_\_

\_\_\_\_\_

To: \_\_\_\_\_

\_\_\_\_\_

\_\_\_\_\_

\_\_\_\_\_

**RE:** Tender No. \_\_\_\_\_

Tender Name \_\_\_\_\_

This is to notify you that the contract/s stated below under the above-mentioned tender have been awarded to you.

\_\_\_\_\_

1. Please acknowledge receipt of this letter of notification signifying your acceptance.
2. The contract/contracts shall be signed by the parties within 14 days of the date of this letter.
3. You may contact the officer(s) whose particulars appear below on the subject matter of this letter of notification of award.





## ANNEXE 1

### PASTORALIST GIRLS INITIATIVE SAFEGUARDING POLICY

Pastoralist Girls Initiative (PGI) is a Registered NGO in Kenya. Pastoralist Girls Initiative (PGI) works to have an empowered pastoralist community able to realize its fullest potential in order to lead a dignified life with a mission of promoting sustainable development by enhancing pastoralist capacities through integrated development approaches. PGI prioritizes five key thematic areas to address poverty, social injustice and underrepresentation in decision making by overcoming challenges of gender disparity in access to education and resources, advocating against retrogressive cultural belief, engage communities on climate changes mitigation and adaptation, strengthening quality health care systems, amplifying women, girl's and indigenous voices. PGI works with various donors, stakeholders, collaborators and service providers in order to realise its vision

VALUES, PRINCIPLES AND BELIEFS AIM: we aim to protect children's rights including adults at risk, partner staff and staff within an organization against all forms of abuse and violence within families, schools, institutions, and communities. We support the prevention of exploitation, harmful traditional practices, and violence against children in their family and community; protection of children living in risky situations in communities; and restoration of children who have been abused, neglected, or exploited. Pastoralist Girls Initiative Safeguarding Policy takes care to be culturally sensitive and legally sound. This policy covers all beneficiaries, staff, Volunteers, Board members, Visitors, Partners, Contractors and others affiliated with partners or contractors. Purpose of Policy: This policy details the standards Pastoralist Girls Initiative will operate by to prevent, monitor, report and respond to harm or abuse suspected or known of all beneficiaries and associates We are committed to creating an environment where potential risks are identified, considered and minimized and there are clear responsibilities and easily accessible processes and procedures to ensure this in all areas of our work. We will meet our commitment to safeguard and protect all people in the following key areas:

- A. Awareness
- B. Prevention
- C. Reporting
- D. Responding

*Empower Girls, Save Community*

## ANNEXE 2

### EVALUATION CRITERIA

a) Preliminary Bid Responsiveness Assessment (Mandatory Requirements)

This will involve assessing whether bidders have complied with submission requirements and have also attached copies of mandatory eligibility and statutory documents. Evaluation at this stage will be conducted on Yes/No, and bidders are expected to comply with ALL required items so as to proceed to the next stage of evaluation.

No.	Completeness and Responsiveness Criteria	Requirement
1.	Valid Tax Compliance Certificate	- Copy of Valid Tax Compliance Certificate
2.	Registration with National Construction Authority	- Copy of Valid National Construction Authority (NCA)
3.	Certificate of Incorporation	- Copy of valid certificate - IDs of the Directors
4.	Two (2) years Audited Accounts (2021 & 2022)	- Copies of Audited Accounts for the last Two years (2021 & 2022)
5.	Bid Security	- Bid Security of 2% of the Total amount Quoted
6.	Proof of Experience	- Submit names/references of three (3) clients where similar services have been successfully implemented within the last two (2) years
7.	Work plan	- A detailed production to delivery work plan/ program
8.	Tender declaration	- Filled form of tender in the format provided
9.	Physical Location	- Copy of Valid Business Permit - Dully filled Business Questionnaires - Declaration and Company Stamp

Responsiveness at preliminary stage shall qualify candidates to Technical Evaluation Stage.

b) Technical Responsiveness Evaluation

Tenders will be evaluated to ensure that they are substantially responsive to the technical specifications and contract conditions stated in the Tender Document. The determination of a tender's technical responsiveness will be based on the contents of the tender itself, subject to any clarifications received in the preliminary examination of Tenders. Items of this evaluation will be scored as below.

Item	DESCRIPTION	POINT Score (marks)
1	EXPERIENCE.	Max 30
	names/references of three (3) clients where similar services have been successfully implemented within the last two (2) years	20
	Completion certificates attached. Attach practical completion certificate ONLY for past successfully delivered projects as evidence	10

2.	KEY PERSONNEL – Technical skill in terms of human resource. Attached CVs and certified copies of academic certificates detailing qualifications of key personnel who shall be involved in these assignments. The persons must be working with the organization or sign on undertaking to work with the firm by the time of submitting this tender throughout the job if awarded	Max 10
3	PLANT AND EQUIPMENT – (Edited as per requirement of the specific job – State the specific machinery required and how many as per the attached table)	Max 10
4.	WORK METHODOLOGY	Max 30
	Program of works logically applicable to this task _To be revised to reflect that the best proposal with respect to the duration how long the Contractor anticipate the job will take gets the most marks	
	Detail Methodology _ Logically articulated	10
	Attach Clear work plan/ schedule of works for execution of project	10
	Methodology on safety, environment and social safeguards	10
	TOTAL	MAX 80
	REMARKS	

NB: The pass mark for technical evaluation will be 70%. Tenders scoring above 70% will proceed to financial evaluation.

c) Financial Evaluation

The maximum number of points assigned to the financial proposal is allocated to the lowest price proposal. All other financial proposals receive points in inverse proportion. The suggested formula is as follows:

$$p = y (\mu/z),$$

p = points for the financial proposal being evaluated,

y = maximum number of points for the financial proposal (here it is 20),

$\mu$  = price of the lowest financial proposal,

z = price of the financial proposal being evaluated

PGI will award the contract to the tenderer whose tender is determined to be substantially responsive to the tender documents and who scored the highest score as per formula below.

The Weights are as follows: -

Technical Proposal, T = 80%

Bid Amount, B = 20%

		Bidder 1	Bidder 2	Bidder 3
	Points			
TECHNICAL PROPOSAL SCORE; (T) - (Prorated to 80%)	80			
BID AMOUNT; (B) - (20%)	20			
Total Points	100			
RANKING		1	2	3

**ADDITIONAL TENDERING FORMS**

(The tenderer to strictly use the provided formats in providing information. The pages may be replicated where more than one is needed)

**PERSONNEL FORM**

Tenderers should provide the names and details of the suitably qualified Contractor's Representative and Key Personnel to perform the Contract.

Position	Name	Years of experience (general)	Years of experience in proposed position

**EQUIPMENT FORM**

The Tenderer shall provide adequate information to demonstrate clearly that it has the capability to meet the requirements for the key equipment listed in Section II, Evaluation and Qualification Criteria. A separate Form shall be prepared for each item of equipment listed, or for alternative equipment proposed by the Tenderer

Item	No.	Make	Model & Year	Owned/Hired	Present Location

## **WORK METHODOLOGY**

- Method Statement
- Mobilization Schedule
- Construction Schedule
- Safety, Environmental & Social safeguards

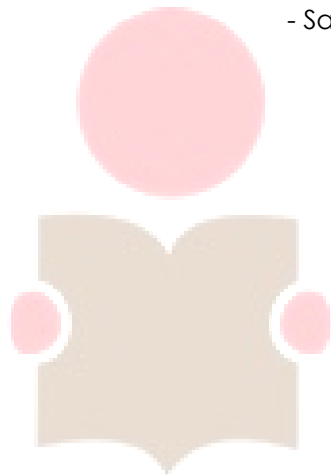

Pastoralist  
Girls Initiative

*Empower Girls, Save Community*

## BILLS OF QUANTITIES

1. The prices and rates inserted in the Bills of Quantities are to be the full inclusive costs of the works described under the items, complete in place and in accordance with the Specifications and Drawings, including setting out of the works, including costs and expenses which may be required in and for the construction of the works described, together with any temporary works and installations which may be necessary and all general risks, liabilities and obligations set forth or implied in the Documents on which the Contract is based
2. The unit rates for the various items listed in the BOQ shall include, except insofar as it is otherwise provided under the Contract, all labor, construction equipment, materials, erection, maintenance, supervision, insurances etc. set forth or implied in the Contract. These are all deemed to include all allowances for waste or surplus of any kind, which are not subject to measurement
3. The rates to be indicated in the Bills of Quantities shall be inclusive of all applicable Government duties and taxes including Value Added Tax (VAT).

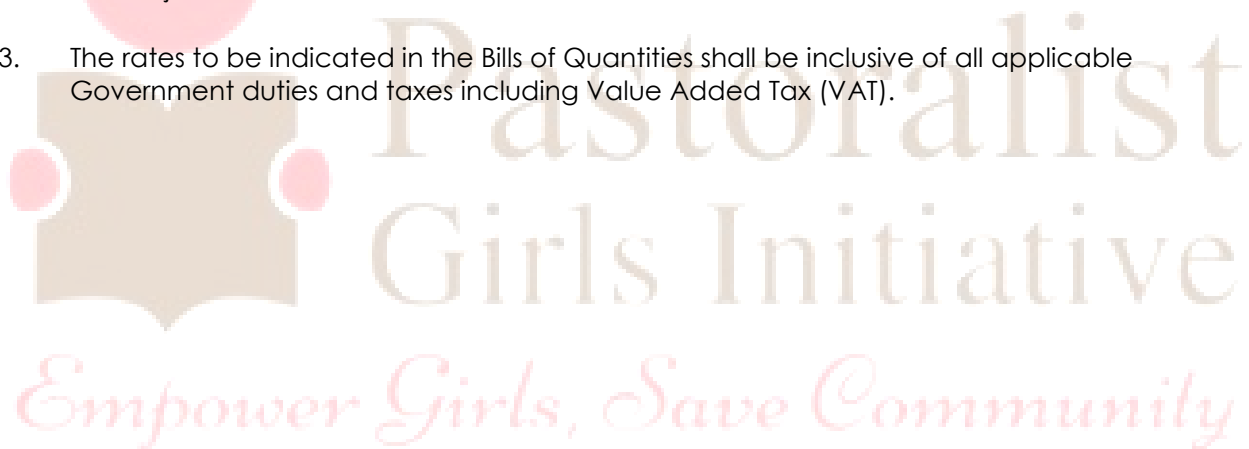

ITEM No.	ITEM DESCRIPTION	UNIT	QUANTITY	RATE (KShs)	AMOUNT (KShs)
	<b>CONSTRUCTION OF BALAMBALA PIPELINES</b>				
The site is located in Balambala village in Balambala Sub-County. The 75mm diameter pipeline starts at the existing rising main (0°02'11"S 39°04'08"E) and terminates at the elevated steel tank location (0°02'04"S 39°03'44"E). The 50mm diameter pipeline starts at the elevated steel tank outlet chamber and terminates at the water kiosk in Bulla Hagal (0°01'32"S 39°03'47"E)					
	<b>CLASS A - GENERAL ITEMS</b>				
	Testing of the Works				
A261.2	Carrying out pressure testing on the HDPE pipelines. Include provision of all equipment and materials	m	1780		
A262	Disinfection of Pipeline ; Flushing with clear water, filling with water containing 0.05g/l Calcium Hypochlorite, left for 24 hours. This includes supply of necessary Equipment, Materials, Chemicals and Water, Measurement of Residual Chlorine, all as specified and safe disposal of disinfecting water.	m	1780		
	<b>CLASS B - SITE INVESTIGATION</b>				
B111	Trial holes to prove location, construction size etc, of pipelines, services or existing structures, max depth ne 1m	nr	5		
	<b>CLASS D - DEMOLITION AND SITE CLEARANCE</b>				
D100	General site clearance through undeveloped land over the wayleave (n.e 1m wide), rate to include for any additional clearance required	m <sup>2</sup>	1780		
	<b>CLASS I: PIPEWORK - PIPES</b>				
	Supply, transport to site, lay and joint pipes in trench. Include for excavation, preparation of surfaces, disposal of excavated material, shoring sides of excavation trenches, backfilling and final reinstatement. Include supply of jointing materials, bolts, nuts, gaskets etc as applicable				
	HDPE pipes with Butt Fusion (seamless) Jointing				

I712. 2	DN75 HDPE pipe PN10 in trenches depth not exceeding 1.0m	m	760		
I712. 3	DN50 HDPE pipe PN10 in trenches depth not exceeding 1.0m	m	1020		
	<b>CLASS J: PIPEWORK - FITTINGS AND VALVES (Including Supply)</b>				
	Supply, Transport to Site, install in Trench, include for Excavation, Preparation of Surfaces, Disposal of Excavated Material, Shoring Sides of Excavation Trenches, Backfilling and Final Reinstatement Include Supply of Jointing Materials, Bolts, Nuts, Gaskets etc as Applicable. All steel fittings to be Epoxy Coated Externally and Internally. All fittings to have a pressure rating of PN 16				
	Steel junctions and Branches				
J321. 0	DN 100x 75 S Flanged Reducing Tee	Nr.	1		
	VJ Stepped Couplings				
J341. 0	DN 100 Stepped Coupling	Nr	2		
	Adaptors				
J351. 1	DN 100S Flanged Adaptor	Nr	1		
J351. 2	DN 75 HDPE PE flange Adaptor (stub end complete with metal back up ring)	Nr	2		
J351. 3	DN 50 HDPE PE flange Adaptor (stub end complete with metal backup ring)	Nr	1		
	Straight Specials				
J381. 0	DN 100 S single Flanged Special spigot pipe 1200mm long	Nr	1		
J381. 1	DN 100 S plain spigot pipe 1200mm long	Nr	1		
	Installation of Valves				
J811	DN 100S Flanged Sluice Valve	Nr	1		
J812	DN 75S Flanged Sluice Valve	Nr	1		
J812	DN 50S Flanged Sluice Valve	Nr	1		
	HDPE Saddle Clamps				
	DN50 x DN 25	Nr	1		
	HDPE End Plug				
J691. 3	DN 50 HDPE End plug	Nr	1		



	Installation of Meters				
J811.3	DN 75S Water meter complete with associated fittings	Nr	1		
	<b>CLASS K: PIPEWORK - MANHOLES AND PIPEWORK ANCILLARIES</b>				
	Excavation quantities are given net. The rates entered are to include for manhole concrete slabs and covers, step irons or ladder, excavation, working space, trimming the base of the excavation, shuttering where necessary, refilling and compacting around the finished manholes, and disposing of surplus spoil local to the trench. Surplus spoil is to be evenly spread.				
K 212.0	Construction of Gate Valve Chambers in accordance with standard drawings; depth not exceeding 1.0m	nr	2		
K 212.0	Construction of Meter Chambers in accordance with standard drawings; depth not exceeding 1.0m	nr	1		
	Crossings				
	The rates inserted here shall cover all work associated with the crossings including provision of sleeves as specified				
K 661	Fence crossing and reinstatement; Pipe nominal bore n.e 300mm	nr	6		
K 681	Allow for crossing existing underground services (specifically community water lines, telephone/electricity ducts, fibre optic cable duct etc.) including reistatement to the original status and liason with the relevant body for inspection/approval during execution of the works. Pilot excavation shall be done to establish exact location of any buried services prior to actual excavation. The rate shall be deemed to include for pilot excavations, repairs and reistatement of any damages to the existing buried services as a result of execution of the works.	sum	1		
	Mass Concrete Surround (Lagga Crossing)				

	Provide all materials and construct 150mm thick class 15/20 mass concrete surround to HDPE pipe under the lagga crossing. Provide polythene Wrapping or approved equivalent on the pipe in two layers as directed by the Engineer before pouring of concrete	m	20		
	Marker Posts				
K822 .1	Marker posts for Gate Valves inscribed GV	nr	2		
K822 .4	Ditto but for Water Main inscribed WM	nr	6		
	Mass concrete class 20/20 in thrust blocks				
	Thrust blocks for bends, tees and blank ends.				
L711 .1	Nominal bore 75mm Tees in GV chambers; volume n.e 0.1 m <sup>3</sup>	nr	1		
	Mass concrete class 20/20 in anchor blocks				
	Anchor blocks for tapers and Gate valves.				
L711	Nominal bore 200mm; volume n.e 0.1 m <sup>3</sup>	nr	1		
	<b>Total- Balambala pipelines</b>				

2Mx2M WATER KIOSK					
ITEM	DESCRIPTION	UNIT	QTY	RATE	AMOUNT
A. SUBSTRUCTURE					
1	Excavate to remove top 300mm soil	m <sup>2</sup>	21		
2	Excavate 1.5m deep foundation trenches	m <sup>3</sup>	5		
3	Allow for backfilling and ramming of excavated material	m <sup>3</sup>	2.5		
4	Cart away surplus excavated material	m <sup>3</sup>	2.5		
5	50mm thick 1:3:6 mix foundation blinding	m <sup>3</sup>	1		
6	1:2:4 mix reinforced concrete in strip foundations, columns	m <sup>3</sup>	1.7		
7	300mm thick hardcore filling on firm foundation base.	m <sup>3</sup>	2		

8	50mm thick murrum blinding on hardcore surface	m <sup>2</sup>	12		
9	Anti-termite treatment	m <sup>2</sup>	12		
10	50mm thick 1:3:6 concrete floor blinding	m <sup>3</sup>	0.4		
11	100mm thick 1:2:4 reinforced concrete floor slab	m <sup>3</sup>	0.6		
12	A142 BRC Mesh	m <sup>2</sup>	5.3		
13	D12 reinforcement to foundation base and column starters	kgs	66		
14	D8 reinforcement to foundation strip	kgs	15		
15	200mm x 25mm softwood sawn formwork to side of slab	m <sup>2</sup>	2		
16	150mm thick foundation masonry walling laid in cement/ sand mortar 1:3	m <sup>2</sup>	8		
<b>B. WALLING</b>					
17	150mm thick 1:2:4 mix reinforced ring beam	m <sup>3</sup>	0.4		
18	150mm thick masonry walling laid in cement/ sand mortar 1:3 reinforced with 25mm wide hoop iron every alternate courses	m <sup>2</sup>	25		
19	200 x 25mm soft wood sawn timber formwork to sides of lintol	m <sup>2</sup>	2		
20	D12mm diameter RC bars. To columns and beams	kgs	40		
21	1:2:4 mix RC to 4No. 200mm x 200mm columns	m <sup>3</sup>	1		
<b>C. ROOFING</b>					
22	200 x 25mm soft wood sawn timber formwork for roof slab. Cost to include supply and fixing of props	m <sup>2</sup>	7		
23	150 x 25mm soft wood sawn timber formwork to sides of roof slab	m <sup>2</sup>	1.2		
24	150mm thick 1:2:4 mix reinforced concrete to roof slab	m <sup>3</sup>	1		
25	D10 RC bars @150mm c/c to roof slab	kgs	45		
<b>D. DOORS</b>					
26	Fabricate, deliver to site and fix standard steel purpose-made door size 1000 x 2000mm. Rate to include painting with one coat of plastic emulsion paint after installation	no.	1		
<b>E. WINDOWS &amp; VENTILATION</b>					

27	Fix standard steel casement purpose-made window size 950 x 1000mm. Rate to include painting with one coat of plastic emulsion paint after installation	no.	1		
28	50mm thick precast concrete window sill all sizes 1000 x 300mm throated/weartherd on the outside	no.	1		
29	Supply 150mm concreter louvre blocks and place in 1:3 cement/sand for 600mm x 300mm vent in wall as shall be directed	l/sum	1		
<b>E. FINISHES</b>					
30	12mm thick plaster to columns, lintel and edges of roof externally	m <sup>2</sup>	20		
	25mm thick cement/ sand screed to floor	m <sup>2</sup>	15		
<b>F. PAINTING</b>					
31	Prepare and apply 3 coats; one undercoat ( 1 u/c) and two coats of gloss paint ( 2 f/c) to columns, lintel and edges of walls externally	m <sup>2</sup>	7		
<b>G. SOAK PIT and APRON</b>					
32	Soak away pit located at the end of the apron. The drainage channel to be linked with soak away pit with a 4inch PVC drainage pipe. The Soak away pit to have 1m Diameter and 1.5metres deep, filled with Hardcore with 1:2:4 reinforced concrete in soak pit cover	no.	1		
33	Construct 2000mmx800mmx100mm, 1:2:4 concrete fetching Apron	m <sup>3</sup>	1		
<b>H. PLUMBING</b>					
34	20mm dia GI pipe	m	2		
35	20mm dia Bend	no.	4		
36	20mm dia Nipples	no.	4		
37	20mm dia Union	no.	4		
38	20mm dia Socket	no.	4		
39	20mm dia water meter. Cost to include all fittings to complete the installation	no.	1		
40	20mm diameter Gate Valve (Peglar)	no.	3		
41	20x20mm equal tee	no.	3		
42	20mm stop cock	no.	1		
43	Allow for connection of the kiosk to the water supply line.	l/sum	1		
<b>I. BRANDING</b>					
44	Allow for branding with partners logos as directed by the Engineer	l/sum	1		
<b>Total Balambala Water Kiosk</b>					

Item No.	Description	Unit	Qty	Rate (Kshs)	Amount (Kshs)
	BALAMBALA BOREHOLE REHABILITATION				
	<b>FENCE INSTALLATION</b>				
1	Clearing the site(30m by 30m) of bushes	m <sup>2</sup>	625		
2	Supply and fix precast concrete posts of size 125x125mm and 2.7m long/high of concrete grade C-20 placed at 3 metres apart c/c with 6 through holes for wire or bolt. The insitu mass concrete surround to be vibrated.	no.	42		
3	Supply and fix 125mmx100mm and 3m long precast concrete strut posts of grade C-20 placed at corners and at the gate	no.	10		
4	Fix on the posts heavy gauge 2.1m high GI chain link mesh stretched and tightly tied. Rate to include providing and fixing GI chain link mesh GI staples (including the cost of GI staples, line wire, earthwork, concrete, struts, steel binding wire etc	m <sup>2</sup>	250		
5	Securing bottom side of the chain-link with mass concrete	l/sum	1		
6	Double leaf gate size 4000x2000mm high comprising 50x100x3mm thick ungalvanized steel rectangular hollow section (RHS) gate posts, 40x25x2mm thick RHS braces, heavy duty Purpose made padlock locking device all welded together and painted to approval. Rate to include painting with one coat of emulsion paint after installation	no.	1		
	<b>Total Fence Installation</b>				-

SUMMARY		
No.	Description	Amount
1	Total- Balambala pipelines	
2	Total Balambala Water Kiosk	
3	Total Fence Installation	
	<b>Grand Total- Balambala Pipelines, kiosk and fencing</b>	

### TECHNICAL EVALUATION CRITERIA

S/NO	Required Information	Maximum marks	Marks awarded
1.	Experience- names/references of three (3) clients where similar services have been successfully implemented within the last two (2) years attached <ul style="list-style-type: none"> <li>• No of projects completed in the last two years</li> <li>• 3 Referees attach proof preferably INGO/NGO</li> </ul>	20	
2.	Experience- Completion certificates attached.	10	
3.	Key Personnel- CVs and certified copies of academic certificates detailing qualifications of key personnel attached	10	
4.	Plant and Equipment -specific machinery required attached	10	
5.	Detail Methodology _ Logically articulated	10	
6.	Clear work plan/ schedule of works for execution of project attached	10	
7.	Methodology on safety, environment and social safeguards	10	
	<b>Total score</b>	<b>80</b>	
	<b>REMARKS</b>		

## FINANCIAL EVALUATION CRITERIA

TENDER FINANCIAL EVALUATION			
TENDER NO. ____ <b>PGI/002/04/2024</b>			
TENDER NAME: Construction of Pipeline Extension, Water Kiosk and Fencing of Borehole Site at Balambala in Balambala ward of Balambala Sub-County, Garissa County			
$p = y (\mu/z)$ p = points for the financial proposal being evaluated, y = maximum number of points for the financial proposal $\mu$ = price of the lowest financial proposal, z = price of the financial proposal being evaluated			
Financial proposal maximum points <span style="float: right;">_____20_____</span>			
*The maximum number of points assigned to the financial proposal is allocated to the lowest price proposal			
S/NO.	FIRM NAME	BID AMOUNT	POINTS

Empower Girls, Save Community

## NON STAFF CODE OF CONDUCT

Pastoralist Girls Initiative is committed to achieving its mission of a just world that advances human rights rights and equality for women and girls.

Suppliers, contractors, vendors & consultants of PGI are considered trusted associates of the organisation. The actions and behaviour of suppliers, contractors, vendors & consultants (whether inside or outside of the PGI offices and environment) can positively impact PGI's ability to achieve its mission but can also undermine PGI's ability to achieve its mission and damage PGIs reputation.

As such, PGI expects all suppliers, contractors, vendors & consultants that it engages with to manage their work and behavior in a way that complies with this Code of Conduct ("**Code**").

This Code applies to all suppliers, contractors, vendors & consultants who are engaged by or on behalf of PGI.

The Code forms part of the contract that a supplier, contractors, vendors or consultant enters into with PGI. **A failure to adhere to the Code could result in that supplier contractors, vendors or consultant's engagement with PGI being terminated.** In agreeing to this Code, suppliers, contractors, vendors & consultants confirm that they also hold their employees, subsidiaries, sub-contractors, consultants, and third parties that they engage accountable to the values and standards in this Code.

The code will include:

- Uphold the integrity and reputation of PGI by ensuring that professional and personal conduct is demonstrably consistent with PGI's values and standards.
- Conduct works and private life in a manner that avoids possible conflicts of interest with the work of PGI's
- Treat everyone with respect and dignity and challenge any form of harassment, discrimination, intimidation, exploitation or abuse.
- To not employ children (under 18).
- To not engage in slavery, forced labour, human trafficking, unfair working practices or inhumane working conditions.
- To create and maintain an environment that treats all employees with dignity and respect and will not use any threats of violence, verbal or psychological harassment or abuse.
- To ensure equality of opportunity and treatment in respect of employment and occupation without discrimination on grounds of race, colour, ethnic background, sex, gender, sexual orientation, age religion or belief and political opinion.



- To immediately report any concerns or suspicions in relation to slavery, forced labour, human trafficking, unfair working practices or inhumane working conditions.
- To ensure the payment of fair wages in full and directly to the workers concerned.
- To fulfill their obligations under local law regarding social contributions & tax payments.
- To maintain full compliance with all laws and regulations applicable to their business.
- Promote human rights, protect the environment and oppose criminal or unethical activities.
- Be responsible for the use of information, equipment, money and resources to which I have access by reason of my association with PGI's
- To not engage in any form of bribery, both giving or receiving.
- To implement measures to prevent opportunities for fraudulent activities to be undertaken by its employees.
- To report any suspected or confirmed incident relating to bribery, fraud or nepotism at the earliest opportunity to PGI and will not withhold any relevant information for any investigation.
- To ensure the proper use of PGI's resources and prevent them from theft, fraud or other damage (where in their control).
- To develop, implement, and maintain processes appropriate to their products to remove the risk of introducing counterfeit parts and materials into deliverable products.
- To report any security or safety incidents occurring where working with, for or on behalf of PGI
- To report any actual, possible or potential conflict of interest and declare to relevant management or a contact within PGI if the supplier or consultant is party to any business relationship with any organisation or person with whom PGI does business if that relationship creates a potential conflict of interest to working with PGI.
- In the event of the assignment you will come into contact with important and sensitive organization data. All information pertaining to this project (documentary, audio, digital, cyber, project documents, etc) belonging to PGI, which you may come into contact with in the performance of your duties under this consultancy/contract shall remain the property of the PGI who shall have exclusive rights over their use. Except for purposes of this assignment, the information shall not be disclosed to the public nor used in whatever form without written permission of PGI

# **DRAWINGS**

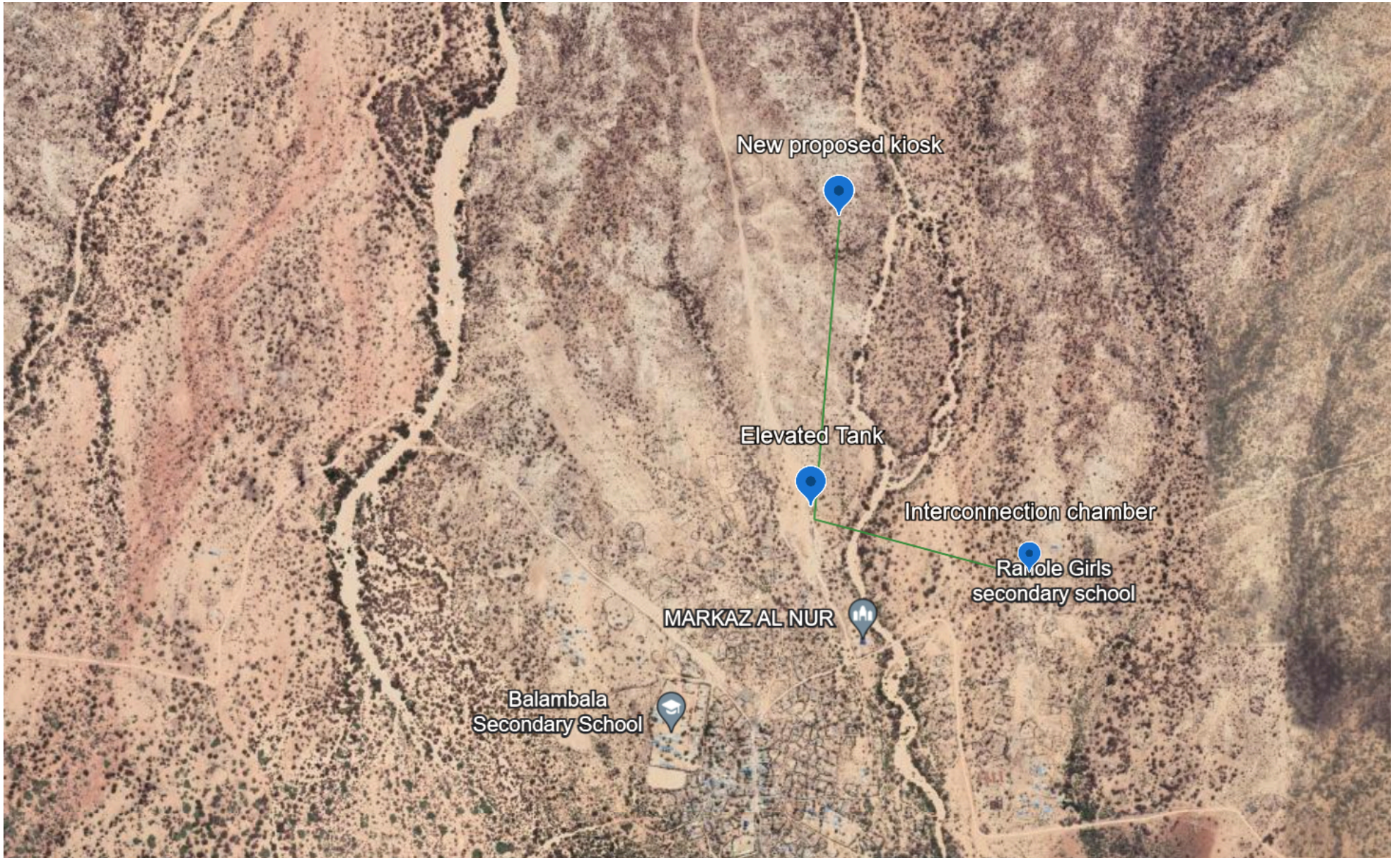

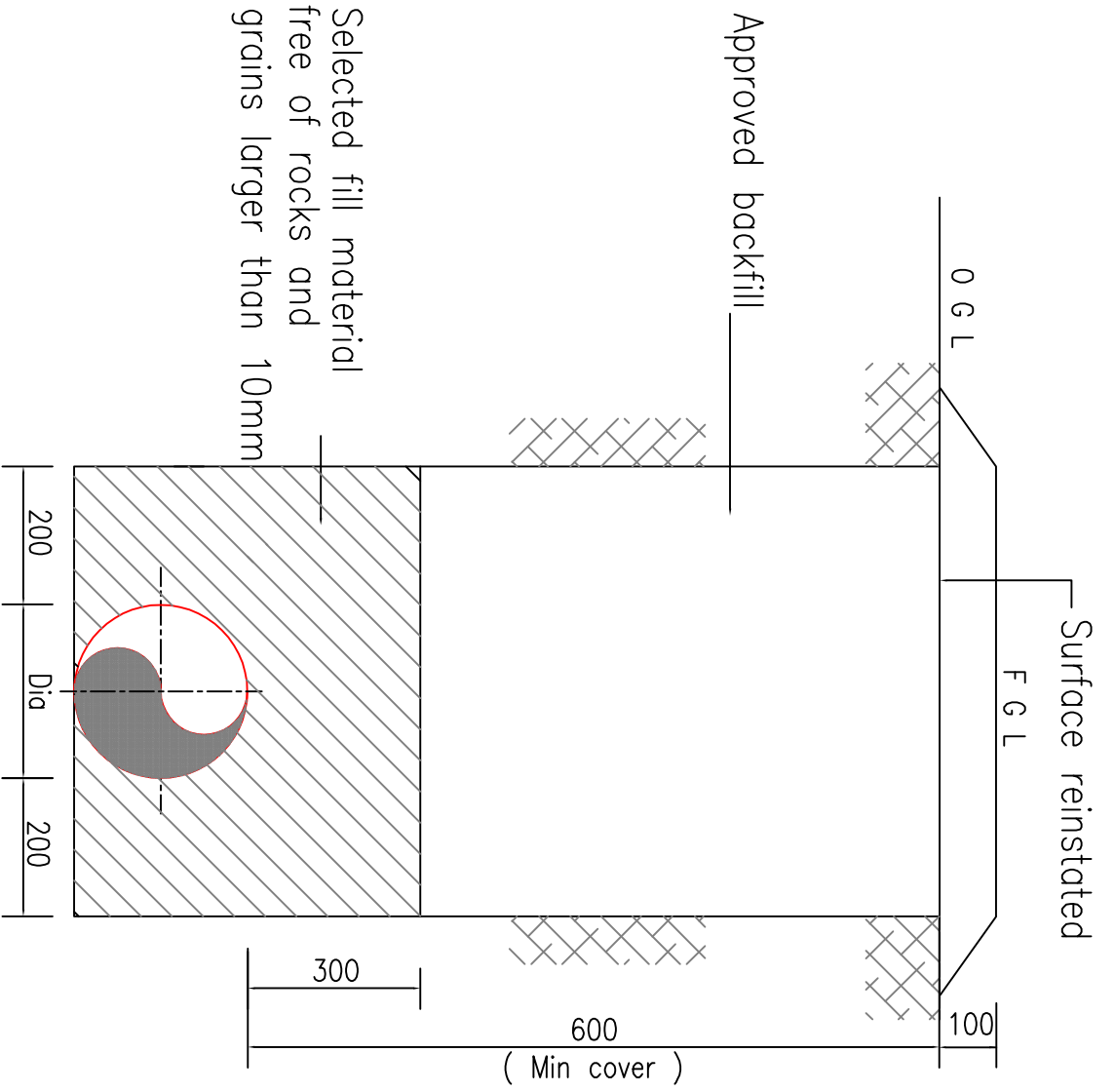

Typical Trench



LETTERING ON INDICATOR POST  
TO BE WL, S.V, WO, A.V.

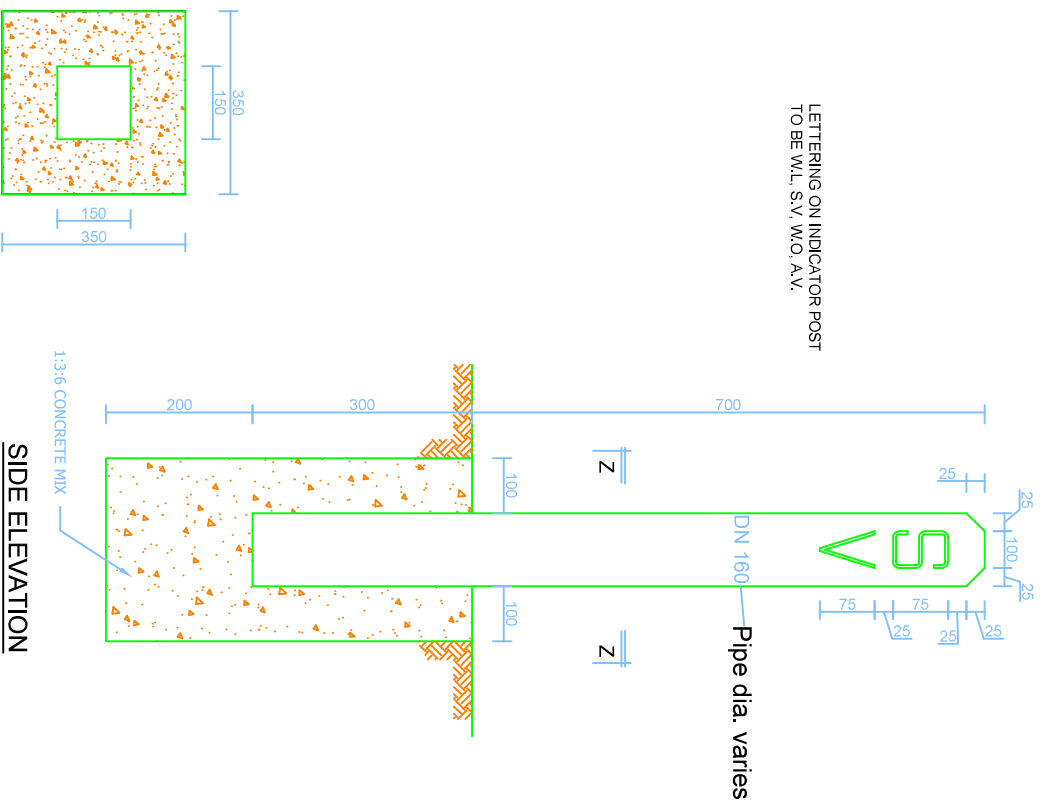

**PLAN**

**SIDE ELEVATION**

**R.C. DETAILS**

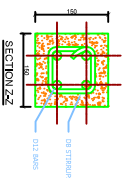

**MARKER POSTS DETAILS**

**NOTES:**

1. All dimensions in millimeters unless stated otherwise.
2. The respective inscription to be made only on one face of the marker post facing the access road
3. All structural concrete to be class 20. All other concrete to be class 15



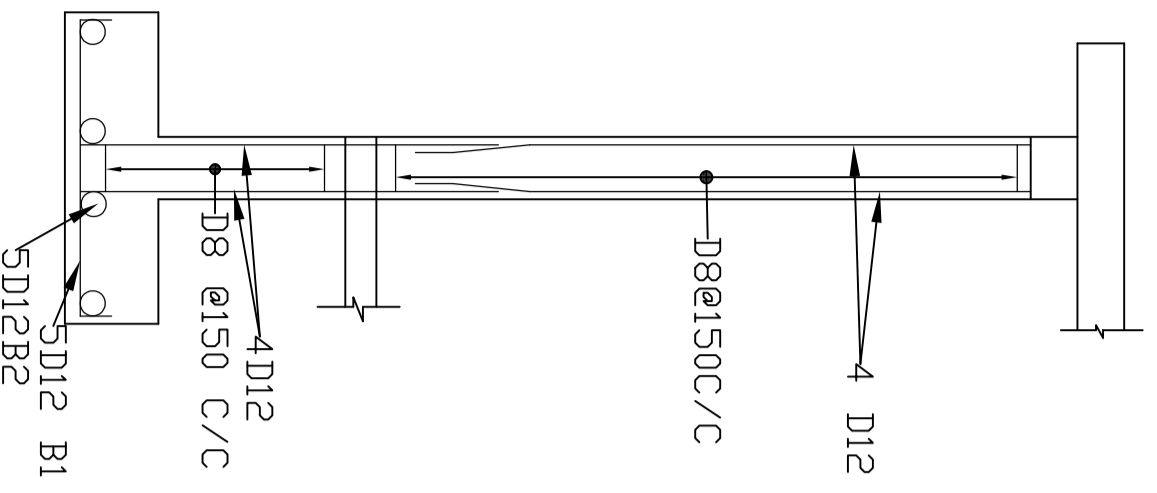

DETAIL FOR COLUMN AND COL. BASE  
Scale 1:25

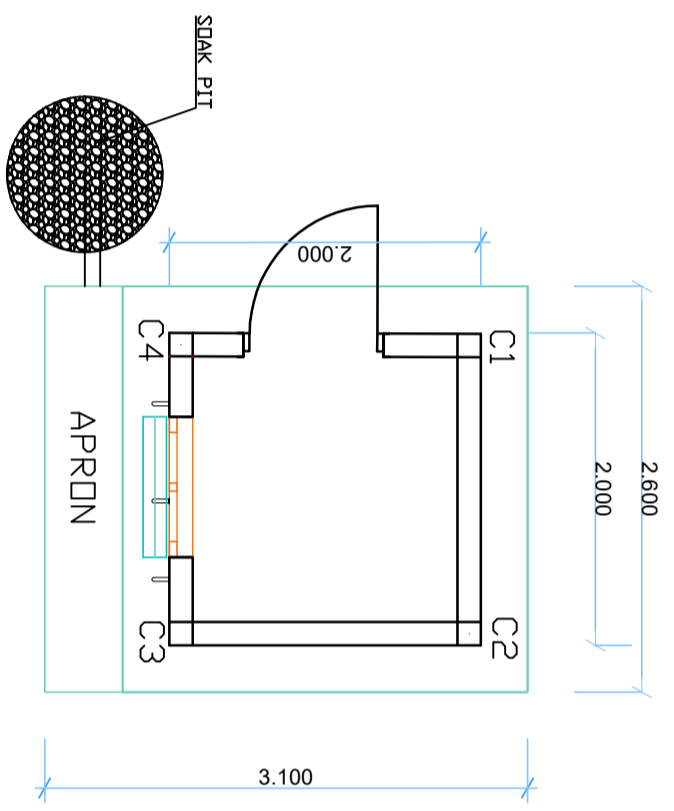

WATER KIOSK PLAN

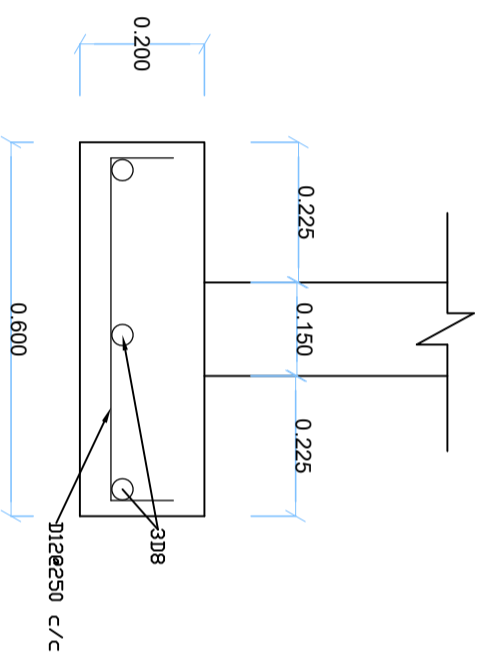

DETAIL FOR STRIP FOOTING  
Scale 1:25

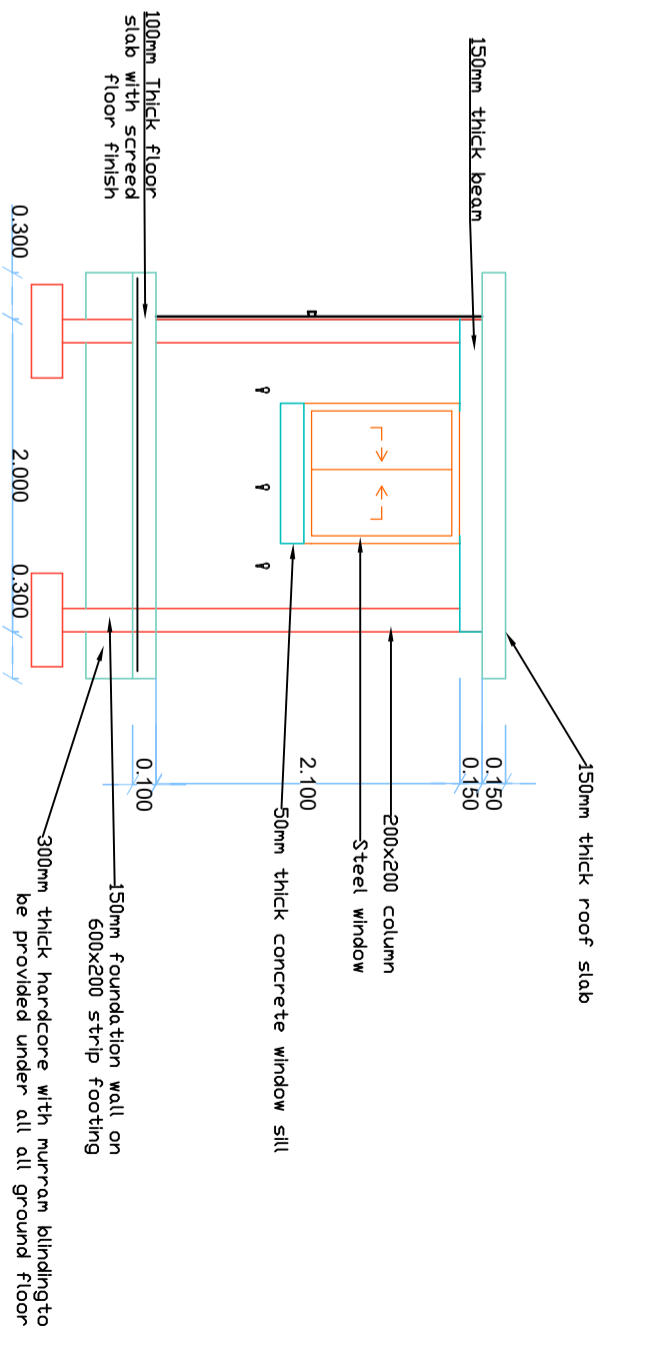

FRONT ELEVATION

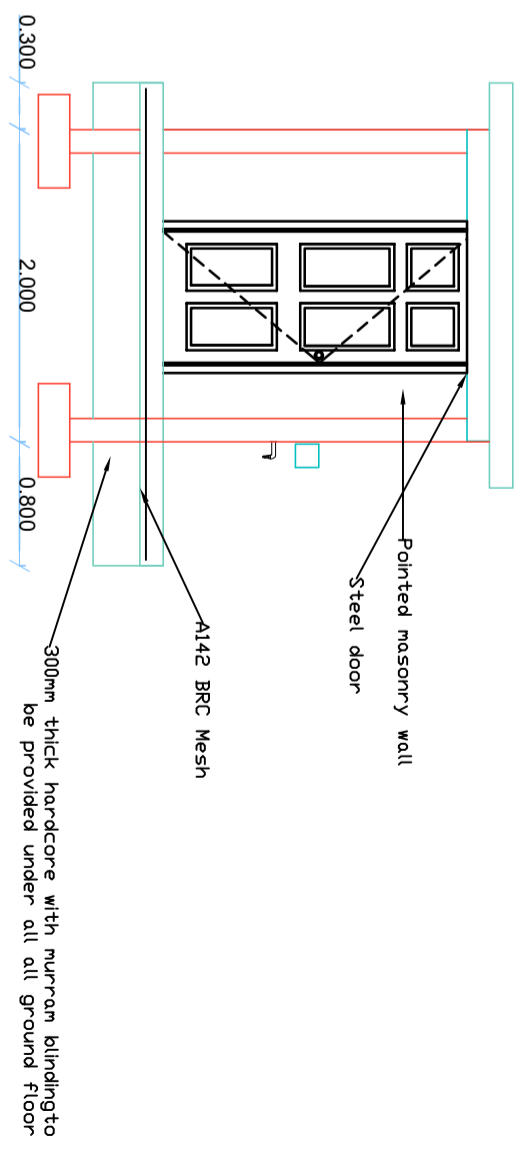

SIDE ELEVATION



CLIENT

DESIGNED BY: LWM  
REVIEWED BY: LWM  
DRAWN BY: LWM

- NOTES
- All dimensions are in mm unless otherwise stated
  - All structural concrete shall be Class25/20
  - Concrete cover to reinforcement  
Columns=40mm  
Foundation=50mm
  - Minimum lap length for all reinforcement bars shall be 50xbar diameter

REV.	AMENDMENT DESCRIPTION	DATE

TITLE: 2Mx2M WATER KIOSK

SCALE Drawing not to scale

Date: April 2024

JOB-DRAWING No. PG100224

REVISION  
A